

FRP

DRAWN BY: K.G.

DATE: 1/15/96

REV DATE:

CK'D BY: DT

CK'D BY:

DOUBLE CONTAINED
PIPING SYSTEMS

DI0010CC

CLOSURE COUPLING

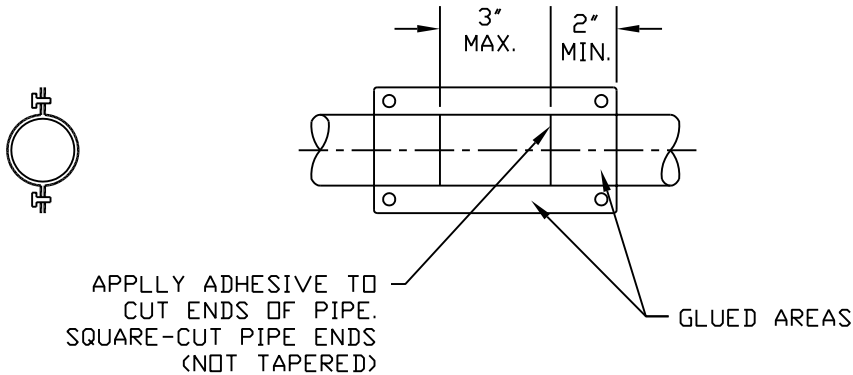

ADHESIVE REQUIREMENT CHART (5oz. KITS)

PIPE SIZE	ADHESIVE REQUIRED
2"	1/2
3"	1/2
4"	1
6"	1

KITS INCLUDES:

- 2 - 180 DEG. HALVES
- 4 - BOLTS AND NUTS
- 1 - REQUIRED EPOXY KITS

- CENTER THE COUPLING AROUND THE GAP IN THE PIPE.
- ABRABE ALL BONDING SURFACES BEFORE APPLYING ADHESIVE.
- COAT THE CUT ENDS OF THE PIPE AND BONDING SURFACES WITH ADHESIVE, THEN BOLT THE COUPLING HALVES TOGETHER.

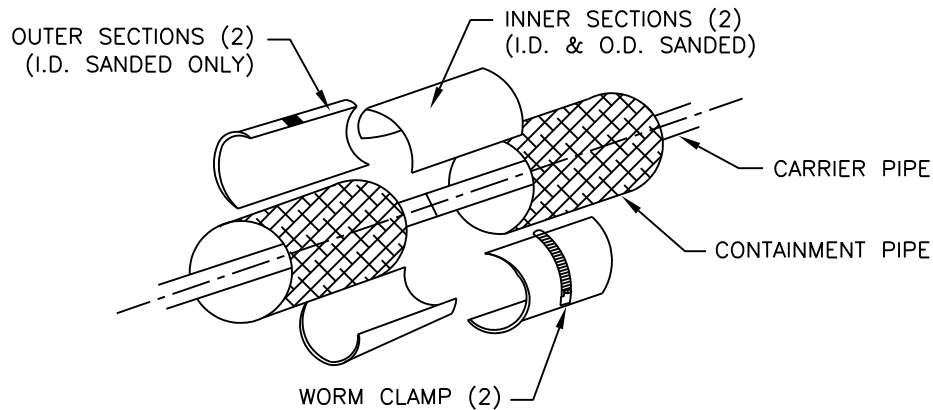

KIT CONTAINS:

- 2-INNER 180 DEGREE FRP SHELLS-- I.D. & O.D. DE-GLOSSED
- 2-OUTER 180 DEGREE FRP SHELLS-- I.D. DE-GLOSSED
- 2-WORM CLAMPS
- 1-EPOXY RESIN/HARDENER BONDING KIT
- 2-MIXING STICKS, GLOVES, SAND PAPER AND A BRUSH

ADHESIVE REQUIREMENT CHART (5oz. KITS)

PIPE SIZE	ADHESIVE REQUIRED
8"	2
10"	3
12"	4

NOTE:

CLOSURE COUPLING MEETS ASTM SPECIFICATIONS:
FRP -D2996