

**330 EXCALIBUR 1.9 SP. GR. "STANDARD PACKAGE OF OPTIONAL EQUIPMENT"**

U.N. MARKING ON TANK READS:

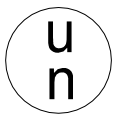

31H2 / Y / MO. / YR. / USA  
 SNYDER IND. INC.  
 LINCOLN, NE. 4455 / 2475  
 CAPACITY - 1249 LITERS  
 TARE MASS - ACTUAL KG  
 GAUGE TEST PRESSURE - 100 KPA  
 LAST LEAKPROOFNESS TEST - MO. / YR.  
 LAST INSPECTION - MO. / YR.

ITEM #	DESCRIPTION	QTY.	PART NUMBER
1	TANK - 1 BUNG TANK WITH 6.5" CAP AND BOTTOM DRAIN HDPE NATURAL. (WITH CAP LANYARD INSERT AND WITH TAMPER EVIDENCE INSERTS MOLDED IN)	1	65145
2	FEET - THREADED HDPE BLACK	4	65049
3	S.I.I. PROPRIETARY 2" NPS REPLACEABLE BUNG GLASS FILLED POLYETHYLENE W/ITON O-RING SEAL	1	N/A
4	2" NPS RIEKE POLYETHYLENE BUNG PLUGS WITH EPDM FLAT GASKETS	1	347340
5	6.5" GEM CAP WITH 2" NPS CENTER OPENING AND EPDM CAP GASKET. EQUIPPED WITH LID TIE	1	347795
6	S.I.I. 2" NPS VACUUM RELIEF VENT WITH EPDM DISK AND FLAT GASKET (AVERAGE GRAVITY FLOW RATE OF 70 GALLONS PER MINUTE)	1	347854
7	2" BANJO STANDARD PORT GLASS FILLED POLYPROPYLENE BOTTOM DRAIN VALVE WITH TEFLON SEATS AND BALL AND 18/8 S.S. BOLTS. INCLUDES DUST CAP AND CAP LANYARD.	1	347718

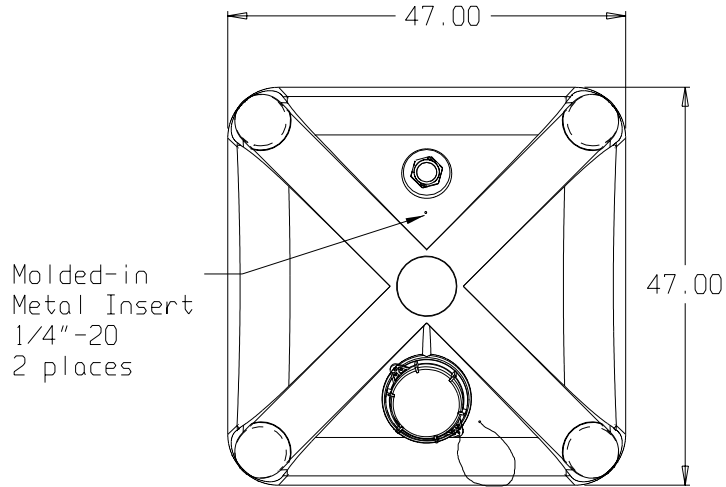

Molded-in Metal Insert  
 1/4"-20  
 2 places

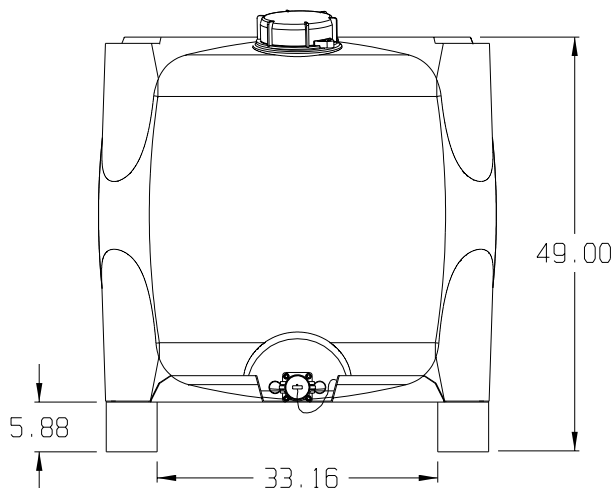

I.D. FILLNECK OPENING 6.25"

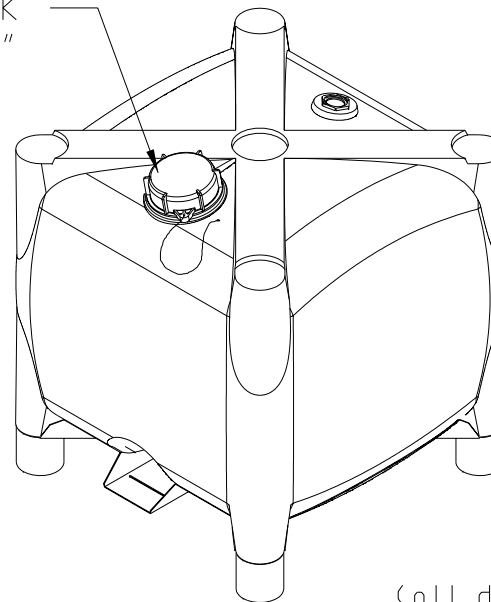

(all dimensions in inches)

TANK PART#: 65145 e 1.9 SPGR

330 GALLON EXCALIBUR 1.9 SPECIFIC GR.

REF#: 0000

08/19/02

SNYDER INDUSTRIES INC.