

+GF+ SIGNET 5090 Sensor-Powered ProPoint™ Flow Monitor



Description

The +GF+ SIGNET 5090 Sensor-Powered Flow Monitor is an economical analog flow rate indicator, with a meter movement powered by the output signal of +GF+ SIGNET 515 Rotor-X and 319/515 Wet-Tap Flow Sensors themselves. No additional power source is required. This unique system is suitable for a wide range of flow rates, and is Factory

Mutual (FM) approved for intrinsic safety without the need for barriers. The NEMA 4X/IP65 integrity of the front panel can be extended to the entire enclosure with the use of an optional Rear Cover Kit, adding to the independence and reliability of this simple flow measuring system, even in the most demanding industrial environments.

Technical Features

Sensor-Powered Flow-Monitoring System Features:

- FM approved – intrinsically safe
- a) The spinning rotor of a Model 515 Flow Sensor induces an AC voltage sufficient to drive the meter movement of a 5090 Flow Monitor
- b) Large, easy to read display with many possible ranges
- c) Cable can be extended up to 200 feet
- d) 1-point calibration adjustment
- e) 1/4 DIN, NEMA 4X/IP65 enclosure

Features

- Sensor-powered flow rate indication up to 200 feet from sensor installation
- Wide flow range: 1 to 20 fps in pipe sizes 0.5" to 36"
- Wet-Tap optional
- Single-point calibration from front panel
- Quality Standards: FM, UL, CSA, CE
- Factory Mutual (FM) approved for intrinsic safety in Classes I, II and III, Division I
- High visibility analog display

Application

- Filtration Systems
- Commercial Pools & Spas
- Hazardous Locations
- Remote Flow Monitoring
- Process Cooling Water
- Distribution Systems
- HVAC
- Process Flow Monitoring

Options

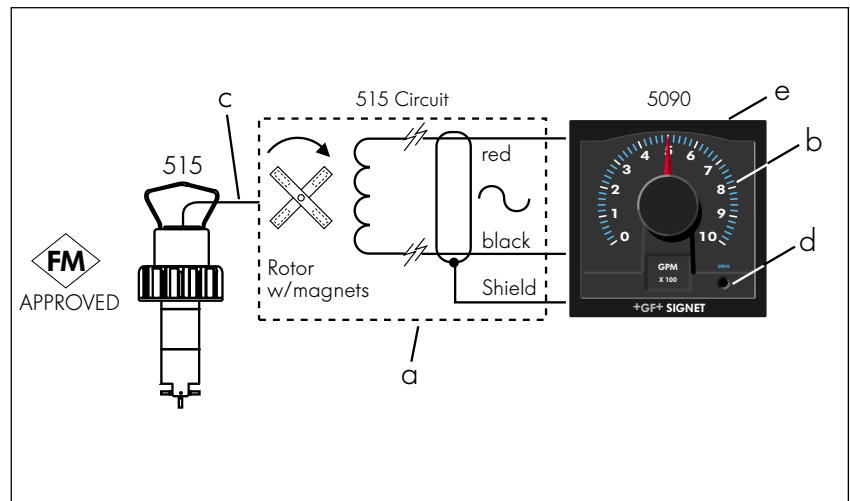
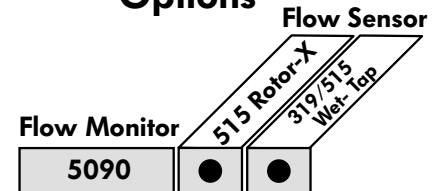

Dimensions

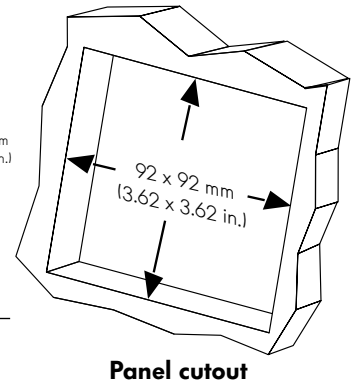
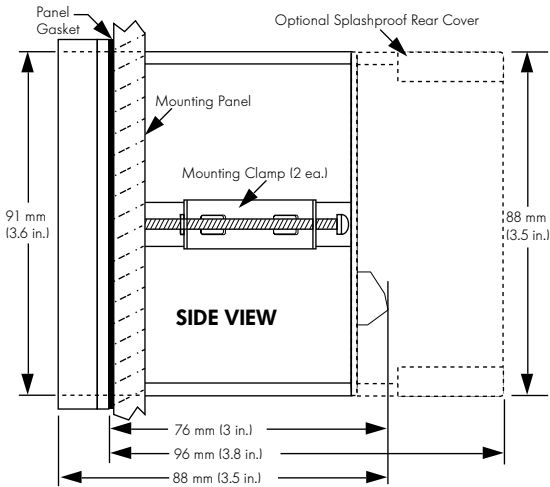
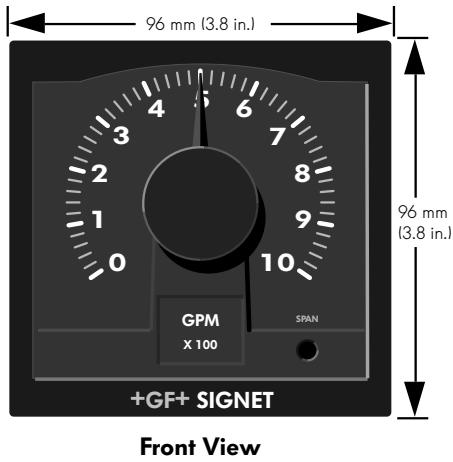

Installation

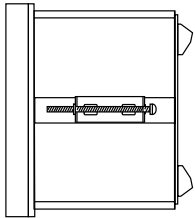

- Panel mount (standard)

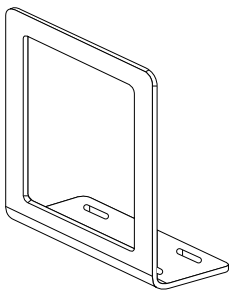

- Optional surface mounting bracket (3-5000.598)

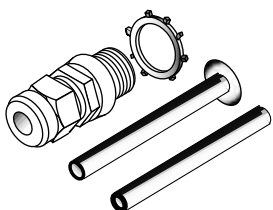

- Liquid Tight Connector Kit - 3 sets per kit (3-9000.392)

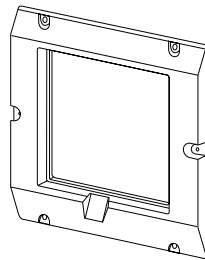

- Optional 5 x 5 inch adapter plate for SIGNET retrofit (3-5000.399)

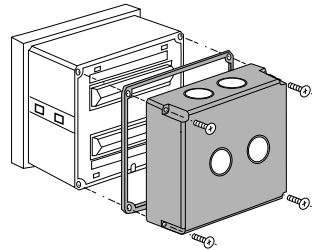

- Optional splashproof rear cover kit (3-5000.395)

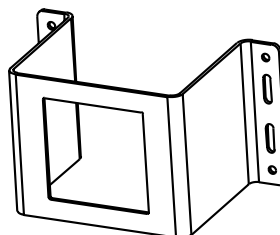

- Optional heavy duty wall mount bracket (3-0000.596)

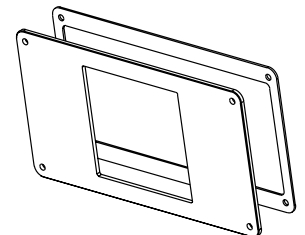

- Optional 200 retrofit adapter (3-8050.392)

- Standard 1/4 DIN panel cutout
- 76 mm (3 in.) mounting depth including rear terminals
- The front panel provides NEMA 4X/IP65 protection.
- Optional splashproof rear cover kit with knockout ports for cable access.
- 96 mm (3.8 in.) mounting depth with optional splashproof rear cover installed
- Up to 60 m (200 ft.) max. cable length between sensor and instrument. Use 2-conductor twisted-pair shielded-cable (22 AWG) wire.

Rear Terminal View

Technical Notes:

- Use 2-conductor twisted-pair shielded cable (22 AWG) for sensor cable splices up to 60m/200ft
- Maintain cable shield through cable splice.
- Route sensor cable away from AC power lines.

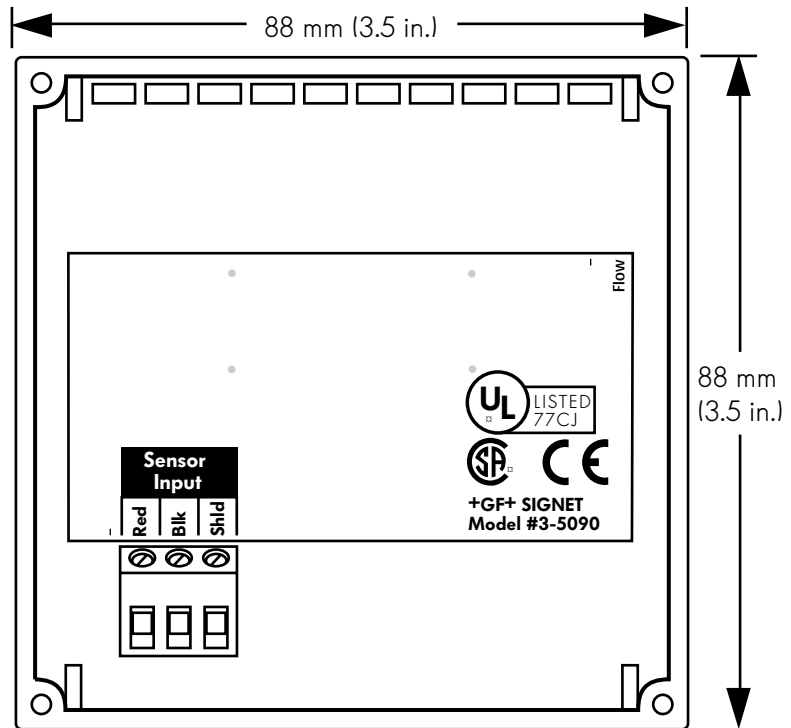

Technical Data

General

Operating Range:	1 to 20 ft/s 7 ft/s (min. full scale range)
Power Requirements:	Sensor-Powered
Display:	Taut-band suspension meter movement, 250° deflection (not suitable for prolonged exposure to vibration)
Accuracy:	±2% of full scale
Repeatability:	±1% of full scale
Materials:	Enclosure: ABS Plastic, NEMA 4X/IP65 Panel and case gasket: Neoprene Window: Hard-coated polycarbonate
Noise Immunity:	EN50082-2
Noise Emissions:	EN55011
Safety:	EN61010-1

Environmental

Operating temperature:	-10 to 65°C (14 to 149°F)
Relative humidity:	0 to 95%, non-condensing

Standards and Approvals

- FM, UL, CSA, CE
- Manufactured under ISO 9001

Ordering Information

Mfr. Part No	Code	Description
3-5090	198 825 000	5090 Sensor-Powered Flow Monitor <ul style="list-style-type: none">• Reversible dial face kit includes ranges 0 to 2, 4, 6, 8, 10 and 100• Assorted flow rate units & multiplier decals also included
P51530-XX*		515 Rotor-X Flow Sensors
MK319/515-XX*		319/515 Wet-Tap Flow Sensors

*See 515 and 319/515 catalog pages for technical and ordering details

Accessories

Mfr. Part No	Code	Description
3-5000.395	198 840 227	Splashproof rear cover kit
3-9000.392	159 000 368	Liquid tight connector kit for rear cover (includes 3 connectors)
3-5000.399	198 840 224	5 x 5 inch adapter plate for Signet retrofit
3-5000.598	198 840 225	Surface mount bracket
3-0000.596	159 000 641	Heavy duty wall mount bracket
3-5000.390	159 000 323	Installation kit
3-5000.396	159 000 325	5090 Window kit
3-5000.525-1	159 000 328	Bezel, 5000 series
3-5090.390	159 000 334	Dial kit
3-5090.611	198 840 228	Unit tags
3-5000.397	159 000 326	5000 Series Window
3-5000.398	159 000 646	Protective Overlay kit (10 pcs.)
3-8050.392	159 000 640	Model 200 Retrofit Adapter

Engineering Specifications

- The flow monitor shall meet appropriate CSA, FM, UL, and CE standards, including EN50082-2 requirements for electromagnetic immunity, EN55011 requirements for electromagnetic emissions, and EN61010-1 for safety.
- The flow monitor shall be manufactured under ISO 9001 certified processes.
- The flow monitor shall be splash proof in adherence with NEMA 4X/IP65 standards.
- The flow monitor shall accept a sinusoidal signal from a compatible flow sensor and convert it to a flow rate display.
- The flow monitor shall include a taut-band suspension meter movement providing a 250° scale.
- For distances up to 200 ft. from the sensor, the flow monitor shall be sensor-powered.
- The flow monitor shall accept replacement dial faces, provided by the manufacturer, to display a variety of engineering units in flow ranges including: 0 to 2, 4, 6, 8, 10 and 100; with multipliers and unit tags.
- The flow monitor shall be compatible with +GF+ SIGNET 515 Rotor-X and 319/515 Wet-Tap Flow Sensors.
- The flow monitor shall be Model +GF+ SIGNET, 5090 Sensor Powered Flow Monitor.