

3-2714_090-1
F-5/98



SAFETY INSTRUCTIONS FOR IN-LINE ELECTRODE USE

1. Do not remove from pressurized lines.
2. Do not exceed maximum temperature/pressure specifications.
3. Do not install/service without following installation instructions.
4. Wear safety goggles and faceshield during installation/service.
5. Do not alter product construction.
6. Failure to follow safety instructions could result in severe personal injury!



WARNING!

When using chemicals or solvents care should be taken and appropriate eye, face, hand, body, and/or respiratory protection should be used.

1. Electrode Features

The +GF+ SIGNET pH/ORP electrode is equipped with the following features for maximum reliability in water and wastewater processes:

- Combination measuring and reference electrodes
- Long reference path for reduced reference contamination potential
- Temperature thermistor (3 kΩ Balco) properly situated for accurate temperature compensation
- Reliable "Twist-lock" connection for easy installation
- Flat surface option for easy cleaning and reduced possibility of fouling

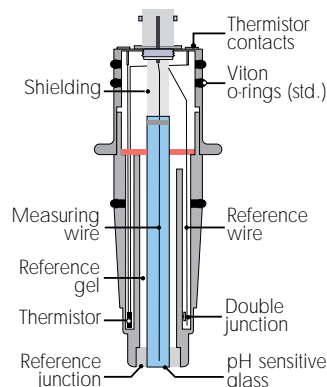

2. Conditions to Avoid

All pH/ORP electrodes are similar to batteries; they age with time and usage. The following information will help maximize electrode life.

2.1 Conditions to Avoid:

- High temperatures, strong acids, or caustics shorten electrode life. To maximize electrode life, avoid pH/temperature extremes whenever possible.
- Coatings on the glass or junction surfaces (i.e. proteins) will prevent proper operation.
- Never store the electrode tip in deionized (DI) water.
- Never expose electrode to freezing temperatures below -12 °C (10 °F) or allow it to dehydrate. These conditions will damage the electrode.
- Never scrape or sand the glass electrode surface.
- Treat glass electrode surfaces with care. The glass is very thin and requires care to prevent accidental breakage.

2.2 Submersible Installation Tips:

- Mount electrode/preamplifier in a location with ample clearance for removal for periodic cleaning and recalibration. Choose a location that keeps the electrode glass completely submerged at all times.
- Place the electrode tip in pH 4 buffer during system maintenance or storage to avoid dehydration.
- Mount the electrode near tank outlet away from reagent addition areas.
- Proper mixing is essential for neutralization. A 10 minute retention time is recommended.

2.3 In-Line Installation Tips:

- pH and ORP electrodes respond best in moving fluids. Flowrates past the electrode should be limited to less than 4 ft/s to maximize life and performance. The internal measuring electrode chamber contains a wire within a liquid and a slight amount of air. The electrode must be mounted vertically $\pm 30^\circ$ to ensure proper sensing. Mounting angles greater than $\pm 30^\circ$ will impede performance.



CAUTION!

The +GF+ SIGNET 3-2720 pH/ORP Preamplifier "twist-lock" seal design keeps all electrical connector surfaces clean and dry. Never allow prolonged exposure of a non-sealed preamplifier and/or electrode contact surface to humid or corrosive environments. To ensure watertight connection, always use o-ring lubrication.



When maintaining an electrode/preamplifier, carefully dry the mating areas with a clean, dry cloth prior to electrode disconnection and installation.

To install Electrode:

1. Align marks and push electrode into preamplifier body
2. Twist right and lock electrode in place

To remove Electrode:

1. Twist left and unlock electrode from preamplifier body
2. Align marks and separate electrode from preamplifier

Do not disassemble preamplifier/sensor assembly while upside down to prevent moisture contamination of preamplifier connections:

3. pH Electrode Calibration

All pH electrodes are designed to ensure linearity during their lifespan. The following sections define proper electrode operation.

3.1 Offset (STD)

Electrode offsets occur due to:

- Clogged reference junction
- Aged or contaminated reference solution/wire

Offsets are easily checked in a pH 7 buffer @ 25 °C; since the theoretical output is 0 mV. Any deviation from 0 mV is the pH electrode offset (i.e. +008 mV).

pH Electrode Offset:

Solution: pH 7 buffer @ 25 °C

- Theoretical: pH 7 = 0.0 mV
- New: pH 7 ±15 mV
- Reliable: pH 7 ±50 mV

Theoretical mV Values @ 25 °C	
pH	mV
2	+ 295 mV
3	+ 236 mV
4	+ 177 mV
5	+ 118 mV
6	+ 59 mV
7	0 mV
8	- 59 mV
9	- 118 mV
10	- 177 mV
11	- 236 mV
12	- 295 mV

Electrode offsets greater than ±50 mV's indicate the electrode requires cleaning or replacement, see section 5 maintenance and cleaning.

3.2 Slope (SLP)

Electrode slope is the number of mV per pH unit. At 25 °C the theoretical slope is 59.16 mV per pH. Temperature can have an appreciable affect on electrode slope. Reliable instrumentation will include temperature compensation. The following graph illustrates potential pH error when a non temperature compensated instrument is used.

°C	pH Error											
	2	3	4	5	6	7	8	9	10	11	12	
15	0.15	0.12	0.09	0.06	0.03	0	0.03	0.06	0.09	0.12	0.15	
25	0	0	0	0	0	0	0	0	0	0	0	
35	0.15	0.12	0.09	0.06	0.03	0	0.03	0.06	0.09	0.12	0.15	
45	0.3	0.24	0.18	0.12	0.06	0	0.06	0.12	0.18	0.24	0.3	
55	0.45	0.36	0.27	0.18	0.09	0	0.09	0.18	0.27	0.36	0.45	

Recommendations:

- Always calibrate solution temperature prior to electrode standard (STD) and slope (SLP) calibration.
- The electrode mV offset will track across the entire pH range. Electrode slope is commonly unaffected by offset changes (i.e. pH 7= +10 mV, pH 4= +187 mV); slope still = +177 mV
- Coatings on the glass surface may affect sensor slopes, see section 5 maintenance and cleaning.
- A constant output near 0 mV in pH 4, 7, and 10 solutions typically indicates a shorted electrode. In these cases electrode replacement is required.

3.3 Response Time/Stability

- New glass bulb type electrodes: 95% response ≤3 seconds
- New flat glass type electrodes: 95% response ≤5 seconds

Response time and stability are affected by the condition of the pH electrode's glass surface (ORP electrode - Platinum surface), reference junction, and reference solution. Restoration to acceptable levels can often be accomplished by cleaning the electrode's glass surface (ORP electrode - Platinum surface) and reference junction.

Electrode mV values should remain stable ±3 mV. Conditions that may cause mV fluctuations are:

1. Electrode coating
2. Excessive flowrates (greater than 4 fps)
3. Ground fault:

3A. Ground faults can be detected by removing the electrode from the application and testing in beakers using pH 4, 7, and 10 buffers or by using a beaker of the process solution. If normal operation is observed in the beaker, yet application stability cannot be achieved, a ground fault probably exists.

3B. Using instrumentation with isolated inputs **and** outputs may restore stable operation.

3C. Solution grounding may restore stable operation.

4. ORP Electrode Calibration

All ORP electrodes are designed to ensure linearity during their lifespan. The following sections define proper electrode operation.

4.1 Offset (STD)

Electrode offsets occur due to:

- Clogged reference junction
- Aged or contaminated reference solution/wire

Offsets are easily checked in pH 7 buffer saturated with Quinhydrone @ 25 °C; since the theoretical output is +87 mV. Any deviation from +87 mV is the ORP electrode offset (i.e. +90 mV). Quinhydrone is the oxidizer measured by the ORP electrode and is required for calibration. To guarantee buffer saturation, mix 1/8g Quinhydrone per 50 mL of pH buffer.

ORP Electrode Offset:

Solution: pH 7 buffer saturated with Quinhydrone @ 25 °C

- Theoretical: pH 7 = +87 mV
- New: pH 7 ± 15 mV
- Reliable: pH 7 ± 50 mV

Electrode offsets greater than ±50 mV's indicate the electrode requires cleaning or replacement, see section 5.2.

4.2 Slope (SLP)

ORP slope errors are generally caused by contamination of the platinum electrode surface. Cleaning the electrode surface will usually restore proper values, response time, and stability.

Common ORP Values

Reaction	EO (V)
Cr → Cr ²⁺ + 2e ⁻	-0.913
Fe → Fe ²⁺ + 2e ⁻	-0.440
Cr ²⁺ → Cr ³⁺ + e ⁻	-0.407
4OH ⁻ → O ₂ + 2H ₂ O + 4e ⁻	-0.401
2I ⁻ → I ₂ + 2e ⁻	-0.400
Ti ²⁺ → Ti ³⁺ + e ⁻	-0.37
Ni → Ni ²⁺ + 2e ⁻	-0.250
Pb → Pb ²⁺ + 2e ⁻	-0.126
Fe → Fe ³⁺ + 3e ⁻	-0.037
H ₂ → 2H ⁺ + 2e ⁻	0.000
Fe ²⁺ → Fe ³⁺ + e ⁻	+0.771
Ag → Ag ⁺ + e ⁻	+0.799
Pb → Pb ⁴⁺ + 4e ⁻	+0.80
3Br ⁻ → Br ₃ ⁻ + e ⁻	+1.06
2Br ⁻ → Br ₂ + 2e ⁻	+1.066
ClO ₂ ⁻ → ClO ₂ + e ⁻	+1.16
Pt → Pt ²⁺ + 2e ⁻	+1.188
Ag → Ag ²⁺ + 2e ⁻	+1.369

Many systems require both pH and ORP calibration. In order to minimize the use of calibration reference solutions, we recommend using pH 7 and 4 buffers for pH calibration first. After pH calibration, ORP calibration can be performed with the same buffers after adding Quinhydrone. Quinhydrone is the oxidizer measured by the ORP electrode and is required for ORP electrode calibration. To guarantee buffer saturation, mix 1/8g Quinhydrone per 50 mL of pH buffer.

5. Maintenance and Cleaning

5.1 Maintenance

Variables can affect long term pH or ORP electrode life. For this reason, a maintenance log is recommended for trend analysis. When storing boxed sensors, lay the sensor flat to maximize hydration of the glass surface. Keep the glass surface wet at all times. Soak the sensor tip in pH 4.0 buffer during system maintenance intervals. In-line applications should be plumbed with a depression (trap) which ensures liquid is maintained around the sensor tip. If sensor dehydration has occurred, soak the sensor tip in pH 4 buffer for 24 to 48 hours, then visually inspect the electrode for surface cracks, swelling, or discoloration.

5.2 Cleaning

Cleaning techniques vary depending on the type of coating present on the glass electrode surface or reference junction.

- **Soft coatings:** can be removed by vigorous stirring, or with directed spray of an applicable detergent or solvent onto the glass electrode surface. Chlorine bleach or mild detergent may be used to remove soft coatings. Always rinse electrode tip in clean water after cleaning.

- **Hard coatings:** can be chemically removed. Always use the least harsh chemical which will remove the contaminant within two (2) minutes without attacking the materials of construction. e.g. calcium carbonate may be removed with a 5% HCL (muriatic acid) solution.
- **Oily or Organic Coatings:** can be removed with detergents or an appropriate solvent that does not attack the materials of construction e.g. isopropyl alcohol may be used but acetone must be avoided to prevent damage to the CPVC sensor body.
- **ORP electrode surface (platinum rod):** can be gently sanded with 600 grit wet and dry silicone or carbide sandpaper, jewelers rouge, crocus cloth, or very fine steel wool.



WARNING!

When using chemicals or solvents care should be taken and appropriate eye, face, hand, body, and/or respiratory protection should be used.

6. Specifications

pH/ORP electrodes

General Specifications

Wetted parts	
Sensor body:	CPVC
O-rings:	Viton®
Electrode junction:	Porous UHMW polyethylene
Quality standard:	CE

+GF+ SIGNET 2714/2714-HF/2716/2716-DI pH Electrodes

Sensor tips:	2714/2714-HF (flat glass), 2716/2716-DI (bulb glass type)
Range:	0 to 14 pH
Response time:	<5 seconds for 95% of signal change @ 25 °C (in calibrated standards)
Temp. compensation:	3 kΩ Balco
Reference Electrode	
Junction type:	Coaxial type (double)
Junction electrolyte:	2714/2714-HF/2716: 3.5 M KCl (front), 3.5 M KCl saturated with AgCl (rear) 2716-DI: 0.1 M KCl (front), 3.5 M KCl saturated with AgCl (rear)
Reference electrolyte:	Ag/AgCl
Sodium error:	None ≤12 pH, <0.2 at 13 pH
Efficiency:	≥97% @ 25 °C (77 °F)
Offset voltage (new):	±15 mV or ±0.25 pH

Impedance:

+GF+ SIGNET 2714/2714-HF:	300 to 500 MΩ @ 25 °C (77 °F)
+GF+ SIGNET 2716/2716-DI:	50 to 100 MΩ @ 25 °C (77 °F)

General Specifications

Maximum pressure/temperature ratings:

- 7 bar (100 psi) max.
@ ≤65 °C (149 °F)
- 4 bar (58 psi) max.
@ ≤85 °C (185 °F)

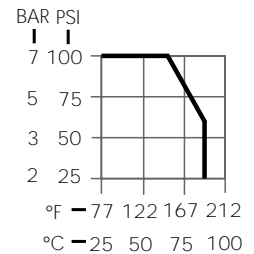

+GF+ SIGNET 2715/2717 ORP Electrodes

Sensor tips:	2715 (flush platinum wire/glass sealed) 2717 (platinum band/bulb type)
Range:	-999 to 1999 mV
Response time:	<5 seconds for 95% of signal change @ 25 °C (in calibrated standards)
Offset voltage (new):	±15 mV
Reference Electrode	
Junction type:	Ag/AgCl double junction
Junction material:	Porous Polyethylene
Junction electrolyte:	3.5 M KCl Gel (front), 3.5 M KCl saturated with AgCl (rear)

Dimensions

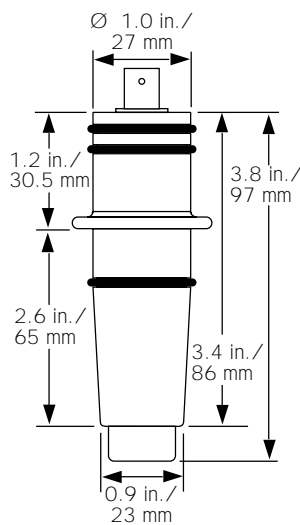

+GF+ SIGNET
2714/2714-HF
Flat pH Sensor

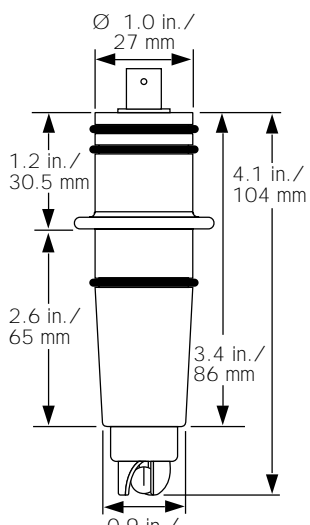

+GF+ SIGNET
2716/2716-DI
Bulb pH Sensor

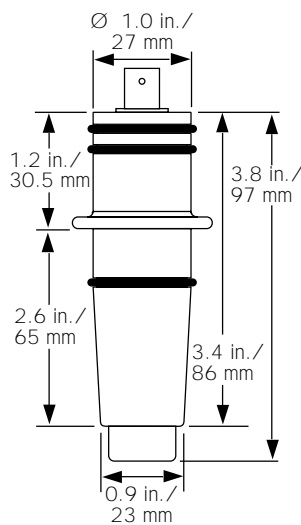

+GF+ SIGNET
2715
Flat ORP Sensor

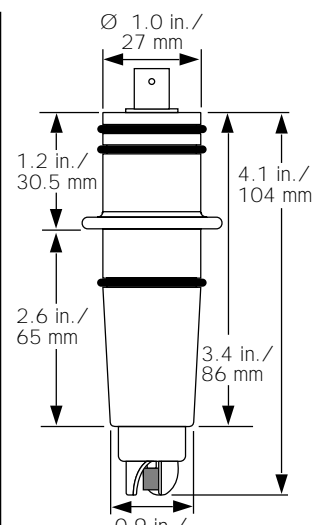

+GF+ SIGNET
2717
Bulb ORP Sensor

7. Spare Parts

Part no.	Description	Material	Code
1220-0021	Sensor O-ring,	Viton®	198 801 186
1224-0021	2 required	EPR	198 820 006
1228-0021		Kalrez	198 820 007



CAUTION!

When replacing O-rings, apply O-ring lubricant to sensor O-rings prior to preamplifier/electrode assembly. Unlubricated O-rings may score the preamplifier sealing surface.

+GF+ SIGNET

Sales Offices:

USA	George Fischer, Inc., 2882 Dow Avenue, Tustin, CA 92780/USA, Tel. (714) 731-8800, Fax (714) 731-6201
Switzerland	Georg Fischer Rohrleitungssysteme AG, P.O. Box 671, CH-8201 Schaffhausen/Switzerland, Tel. 052/631 1111, Fax 052/631 2830
Singapore	George Fischer Pte. Ltd., 15 Kaki Bukit Road 2, KB Warehouse Complex, Singapore 1441, Tel. 65/747 0611, Fax 65/747 0577
Japan	Kubota George Fischer, 2-47 Shikitsuhigashi, 1-Chome, Naniwa-Ku, Osaka, 556-91 Japan, Tel. 816/648 2545, Fax 816/648 2565
China	Georg Fischer Ltd., Rm 1503, Business Residence Bldg. of Asia Plaza, 2-3 Bldg. No. 5th Qu Anzhenxili, Chaoyang Qu, Beijing 100029, P.R. China, Tel. 86/10 6443 0577, Fax 86/10 6443 0578
Australia	George Fischer Pty. Ltd., Suite 3, 41 Stamford Road, Oakleigh, Victoria 3166, Australia, Tel. 61/3 9568 0966, Fax 61/3 9568 0988

Signet Scientific Company, 3401 Aerojet Avenue, El Monte, CA 91731-2882 U.S.A., Tel. (626) 571-2770, Fax (626) 573-2057