

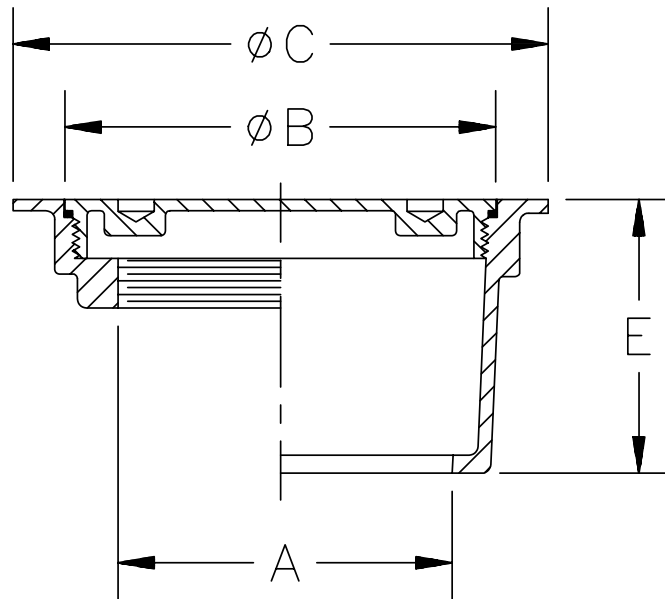

Z-1456 DECK CLEANOUT

TAG _____

Dimensional Data (inches and [mm]) are Subject to Manufacturing Tolerances and Change Without Notice



Dimensions In Inches					Approx. Wt. Lbs. [kg]
A Pipe Size	IC		IP		
	B	C	B	C	
2 [50]	3 1/2 [89]	4 3/4 [121]	2 3/4 [70]	4 [102]	3 [1]
3 [75]	5 [127]	6 [152]	3 1/2 [89]	4 7/8 [124]	4 [2]
4 [100]	6 [152]	7 3/8 [187]	4 1/2 [114]	6 [152]	6 [3]
5 [125]	8 [203]	9 3/8 [238]	7 7/8 [200]	9 3/8 [238]	10 [5]
6 [150]					12 [5]
8 [200]	9 7/8 [251]	11 [279]	9 7/8 [251]	11 [279]	16 [7]

ENGINEERING SPECIFICATION:
ZURN ZANB-1456 Deck cleanout, nickel bronze body with scoriated deck plug and O-ring seal.

OPTIONS (Check/specify appropriate options)

PIPE SIZE

2 thru 6 [50 thru 150]
2 thru 6, 8 [50 thru 150, 200]

(Specify size/type) **OUTLET**

_____ IC Inside Caulk
_____ IP Threaded

'E' BODY HT. DIM.

3 1/4 [83]
1 1/2 [38]

PREFIXES

_____ ZAB- Bronze with Polished Scoriated Top*
_____ ZANB- Nickel Bronze with Polished Scoriated Top

SUFFIXES

_____ -DX Dex-o-tex Flange
_____ -SP Spanner Wrench

REV. B	DATE: 3/5/97	C.N. NO. 77583
DWG. NO. 58773	PRODUCT NO. Z-1456	

*REGULARLY FURNISHED UNLESS OTHERWISE SPECIFIED