



Z-1454

ADJUSTABLE FLOOR CLEANOUT WITH FLASHING FLANGE

SPECIFICATION SHEET

TAG _____

Dimensional Data (inches and [mm]) are Subject to Manufacturing Tolerances and Change Without Notice

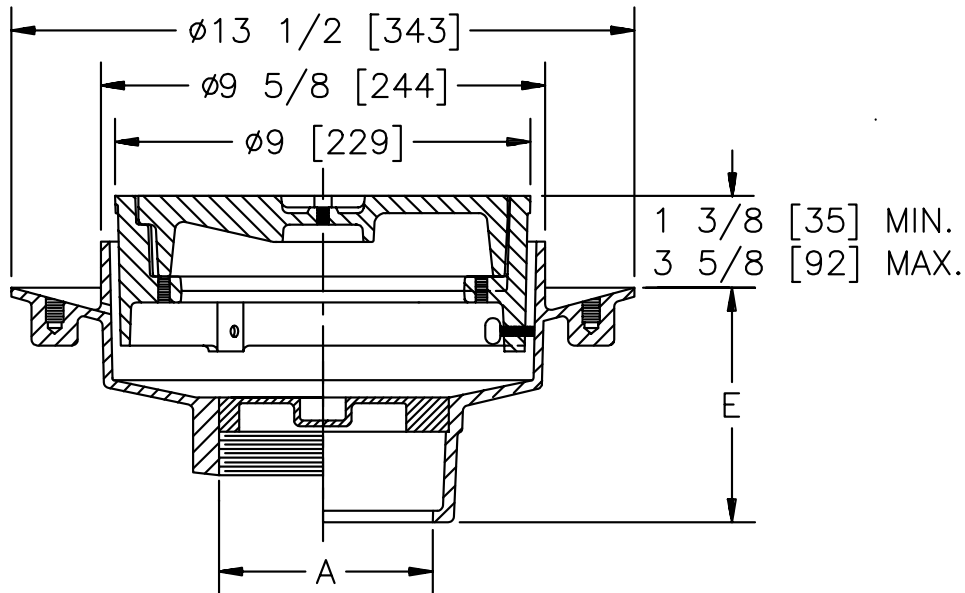

A Pipe Size Inches	Approx. Wt. Lbs [kg]
2-3 [50-75]	33 [15]
4 [100]	34 [15]

ENGINEERING SPECIFICATION: ZURN Z-1454 Adjustable Floor cleanout, Dura-Coated cast iron body, gas and watertight ABS tapered thread plug, and round scoriated Dura-Coated cast iron adjustable top, complete with membrane flashing flange.

OPTIONS (Check/specify appropriate options)

PIPE SIZE	(Specify size/type) OUTLET	'E' BODY HT. DIM
2, 3, 4 [50, 75, 100]	___ IC Inside Caulk	5 1/4 [133]
2, 3, 4 [50, 75, 100]	___ IP Threaded	4 1/4 [108]

PREFIXES

- ___ Z- Dura-Coated Cast Iron.*
- ___ ZB- D.C.C.I. with Polished Bronze Scoriated Top (Add 3/16 [5] to 1 3/8 [35] Min.- 3 5/8 [92] Max.)
- ___ ZN D.C.C.I. with Polished Nickel Bronze Scoriated Top (Add 3/16 [5] to 1 3/8 [35] Min.- 3 5/8 [92] Max.)

SUFFIXES

- ___ -A Raised Head Plug
- ___ -C Clamp Collar
- ___ -DC Duresist Cover
- ___ -G Galvanized Cast Iron
- ___ -TS Top Secured with Slotted Screws
- ___ -VP Vandal Proof Secured Top

REV. C	DATE: 3/5/97	C.N. NO. 77581
DWG. NO. 58771	PRODUCT NO. Z-1454	

*REGULARLY FURNISHED UNLESS OTHERWISE SPECIFIED